

DF550L HIGH-PERFORMANCE HYDRAULIC ROCK DRILL

Doofor DF550L is a high-frequency hydraulic rock drill specially designed for underground production drilling and tunneling. The DF550L has a very low overhead, only 84mm from the drill center line. The rotation motor of the DF550L can be installed on the right-hand or the left-hand side. The rock drill can use air or water flushing.



TECHNICAL SPECIFICATIONS

DOOFOR DF550L DRIFTER

NOMINAL PERCUSSION POWER		17 kW	22.8 hp
OPTIMAL MAXIMUM HOLE SIZE		76 mm	3"
PERCUSSION FLOW		90-120 l/min	23.8-31.7 gpm
PERCUSSION PRESSURE		80-160 bar	1160-2321 psi
ROTATION MOTOR MAXIMUM FLOW ¹⁾	80cc	80 l/min	21.1 gpm
	100cc	90 l/min	23.8 gpm
	125cc	90 l/min	23.8 gpm
	160cc	90 l/min	23.8 gpm
	200cc	90 l/min	23.8 gpm
ROTATION TORQUE ¹⁾	80cc	504 Nm	372 lb-ft
	100cc	634 Nm	468 lb-ft
	125cc	796 Nm	587 lb-ft
	160cc	975 Nm	719 lb-ft
	200cc	1170 Nm	863 lb-ft
ROTATION PRESSURE MAXIMUM		175 bar	2540 psi
ROTATION SPEED MAXIMUM	80cc	250 rpm	
	100cc	250 rpm	
	125cc	250 rpm	
	160cc	250 rpm	
	200cc	250 rpm	
LUBRICATION	Air-oil mist	200-300 g/h	7.8-11.7 fl oz/h (2.3-3.5 dl/h)
LUBRICATION PRESSURE		6-7 bar	87-101 psi
LUBRICATION AIR FLOW		200-300 l/min	53-79 gpm
FLUSHING AIR PRESSURE ¹⁾		5-7 bar	73-101 psi
FLUSHING AIR FLOW ¹⁾		4000 l/min	1057 gpm
FLUSHING WATER FLOW ¹⁾		50-150 l/min	13-40 gpm
FLUSHING TEMPERATURE		3-30°C	37-86°F
RECOMMENDED MAXIMUM FEED FORCE		15 kN	3372 lbf
MAXIMUM OPERATING OIL TEMPERATURE		70 °C	158 °F
WEIGHT		152 kg	335 lb
SHANK SIZE		R32, R38, T38, T45	

¹⁾ Intermittent value.

²⁾ Actual values vary according to drilling conditions and equipment.

DIMENSIONS

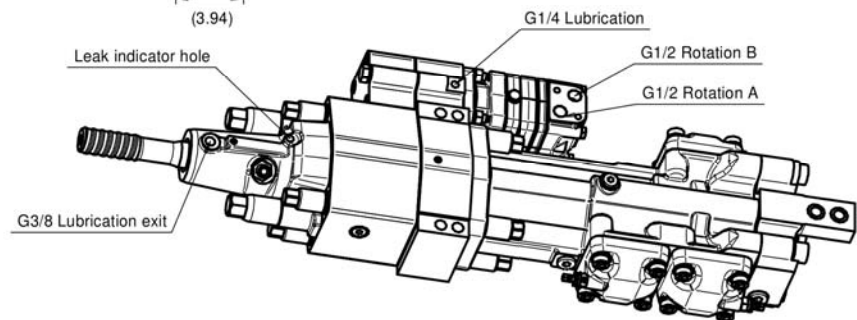
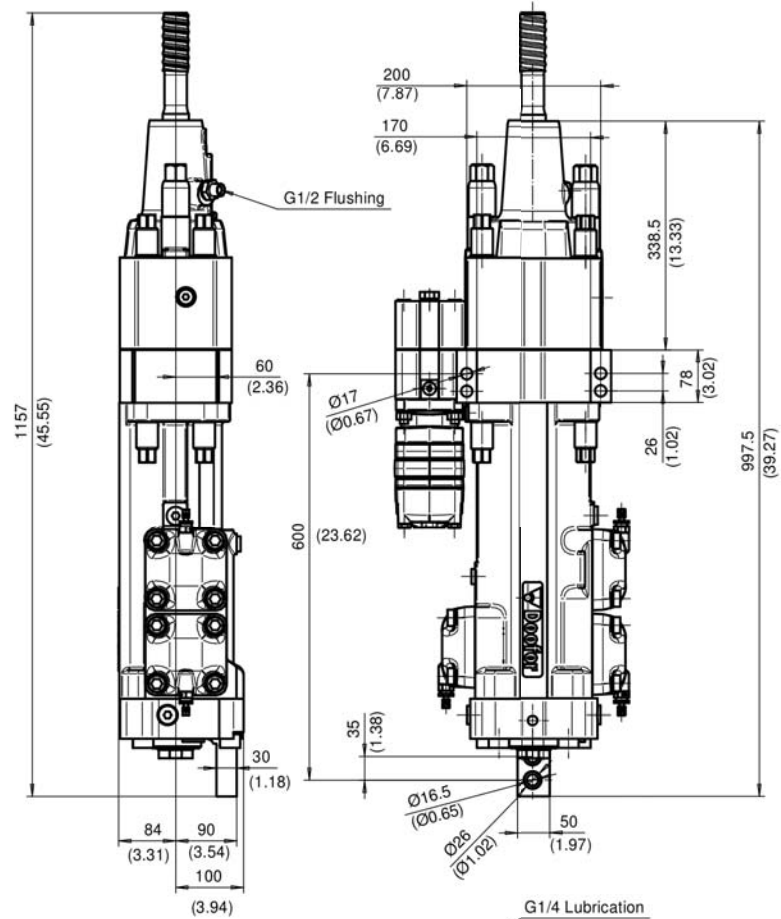
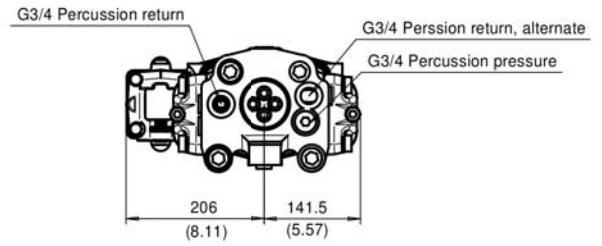

Rotation motor can be turned in 90° steps. Motors with back ports are available.
 Gear box can be turned 180 degrees.
 Flushing head can be turned 180 degrees.

DF550L can be equipped with BLT, EXT- and 2M options.